



# LMI Solutions

Covid19 Safety Solutions

# Health Barriers & Social Distancing Systems

- ▶ Take advantage of a wide range of standard or custom solutions, delivered as a kit or assembled. Get protection for your employees, customers, patients and students - Let LMI Solutions meet your needs.

## Gel dispenser posts & cleaning stations

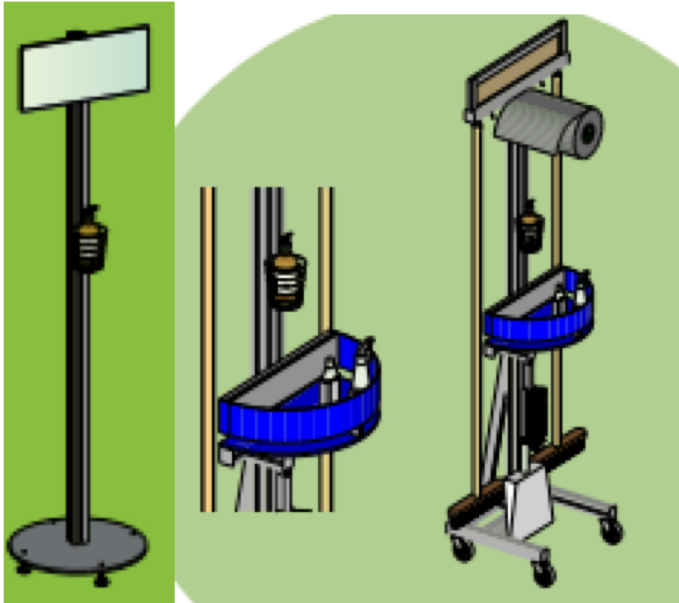

## Entry SAS & door modules

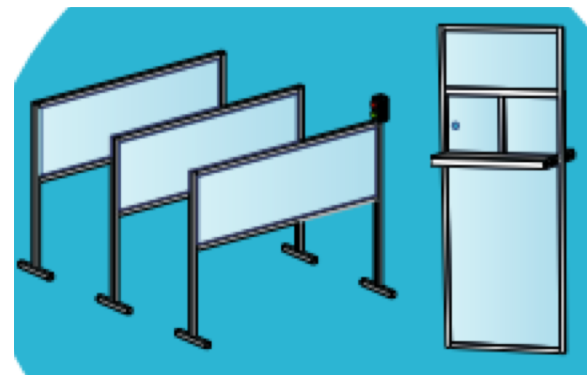

## Freestanding or counter screens

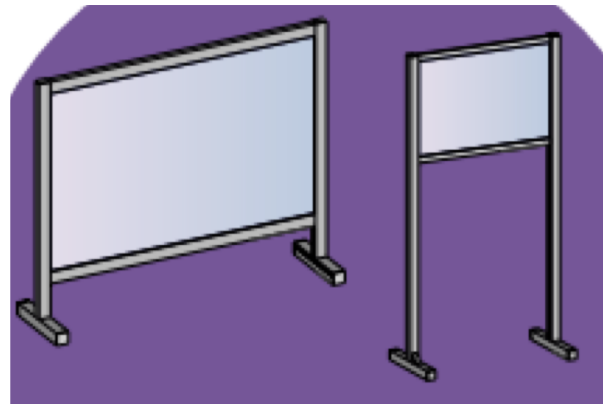

# Solutions for the workshop

## ► Moveable Vertical Separators

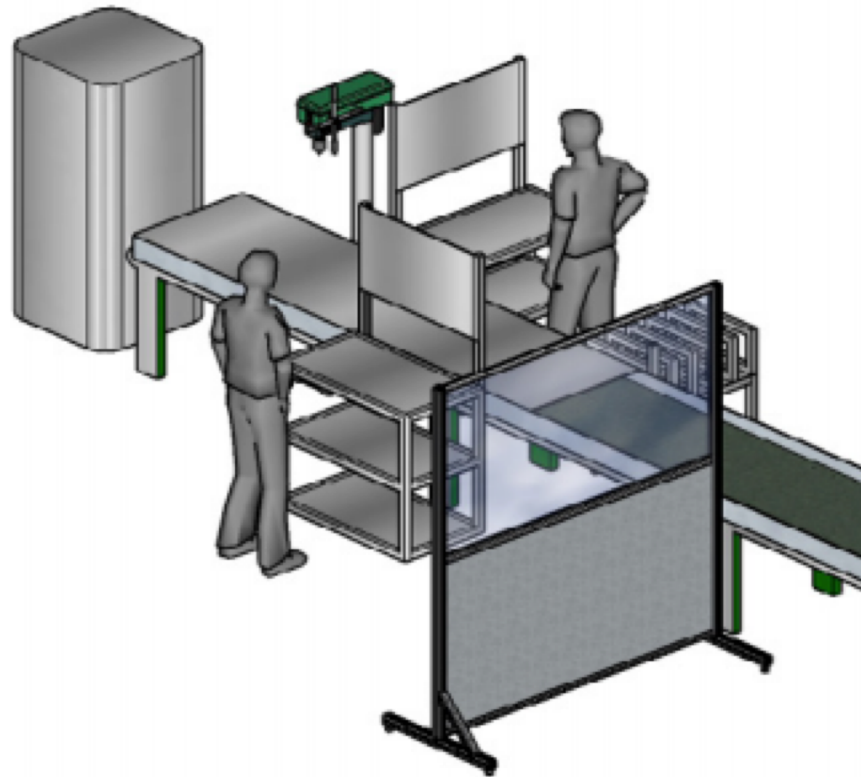
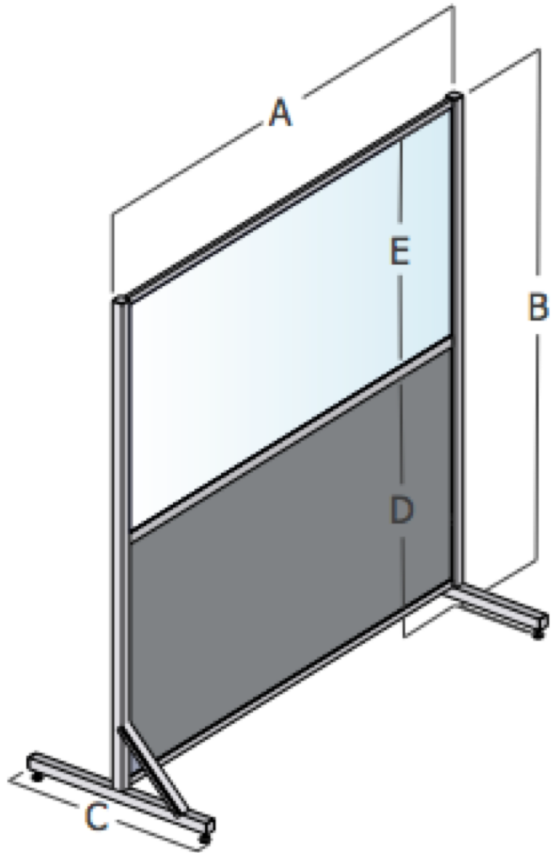

# Counter Screens

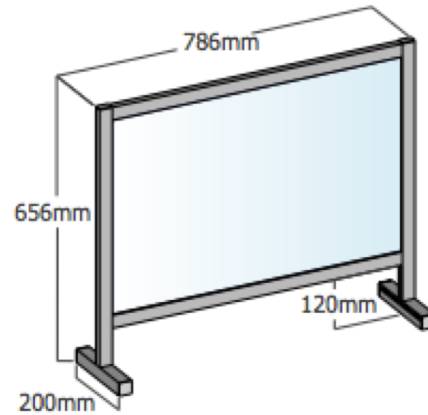
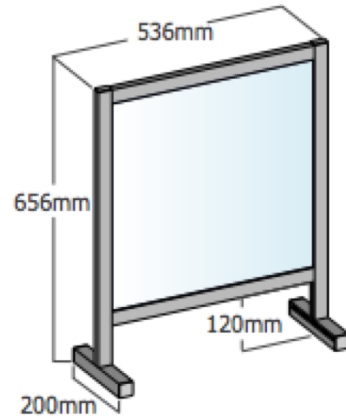
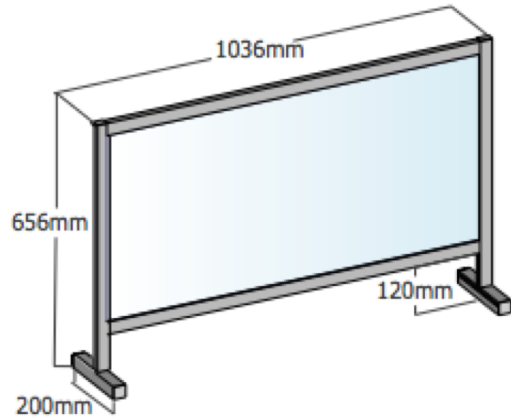
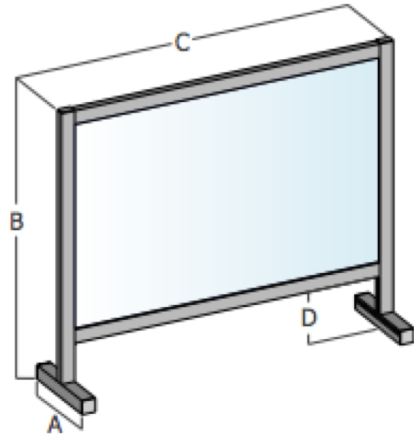



# Floor Standing Screens

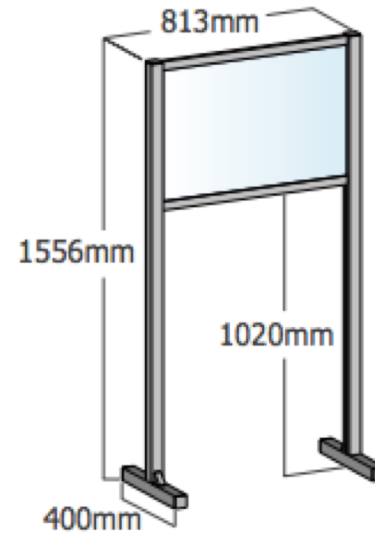
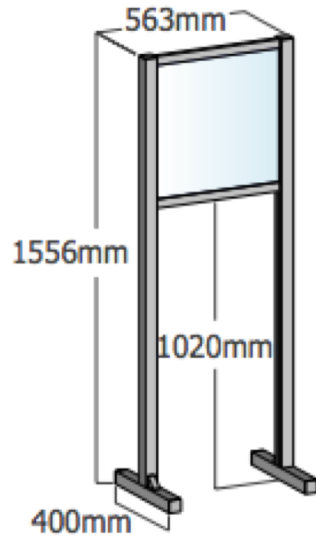
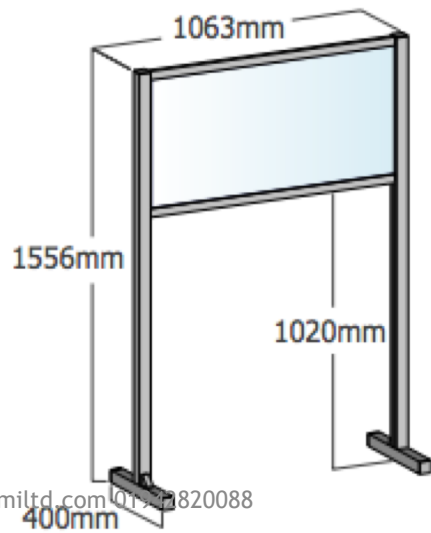
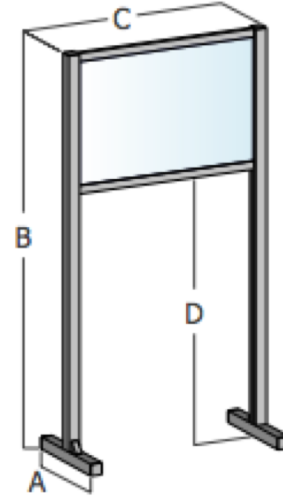
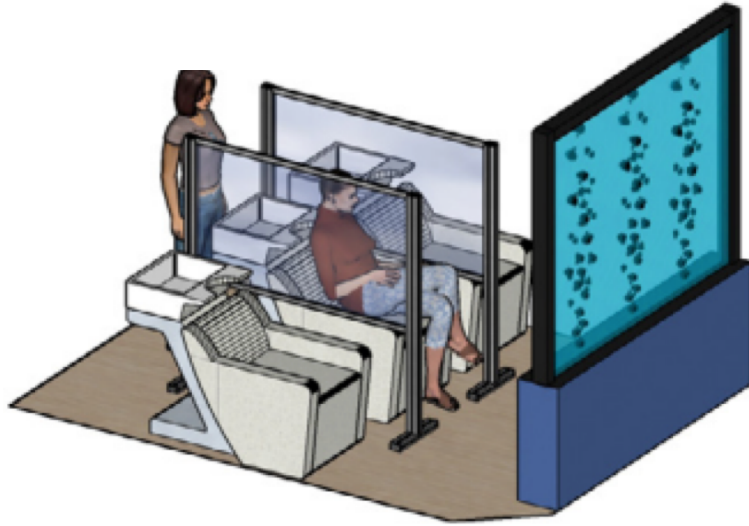

# Entry SAS & Door Modules

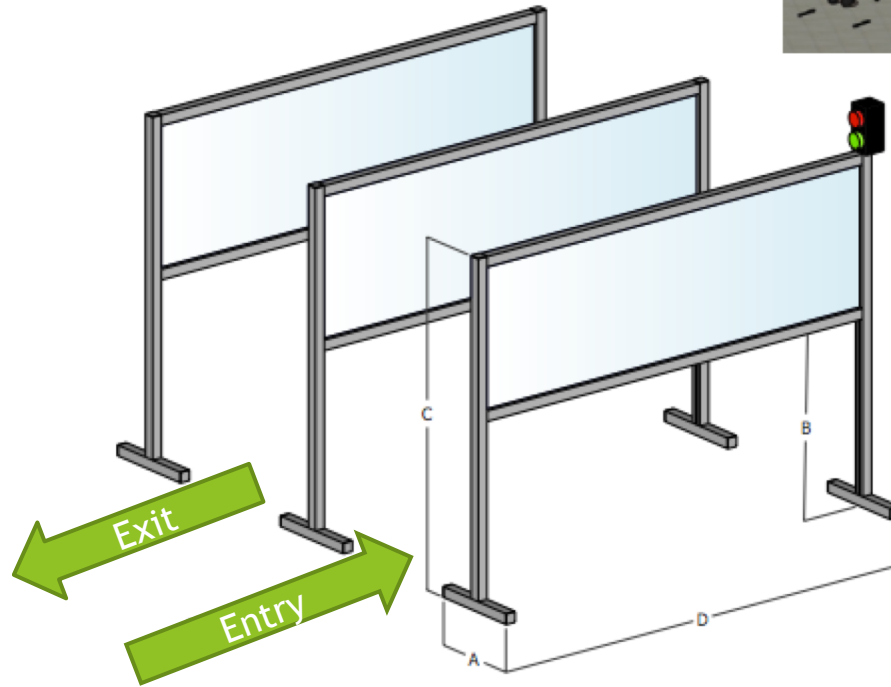

# Door Modules

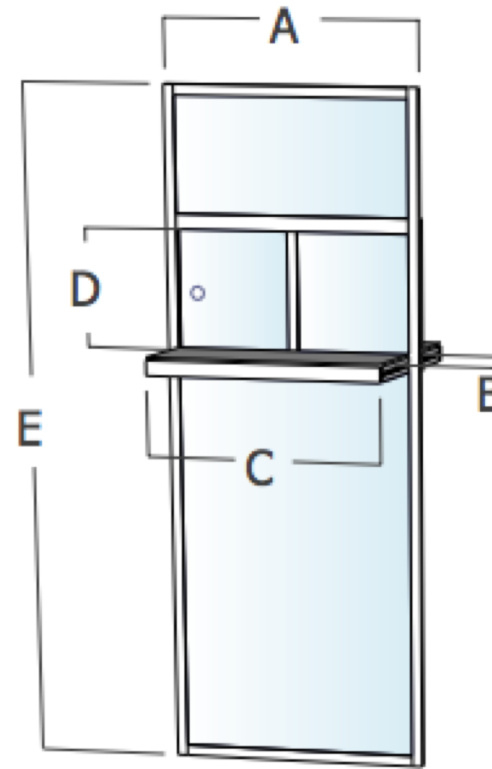

# Cleaning Station

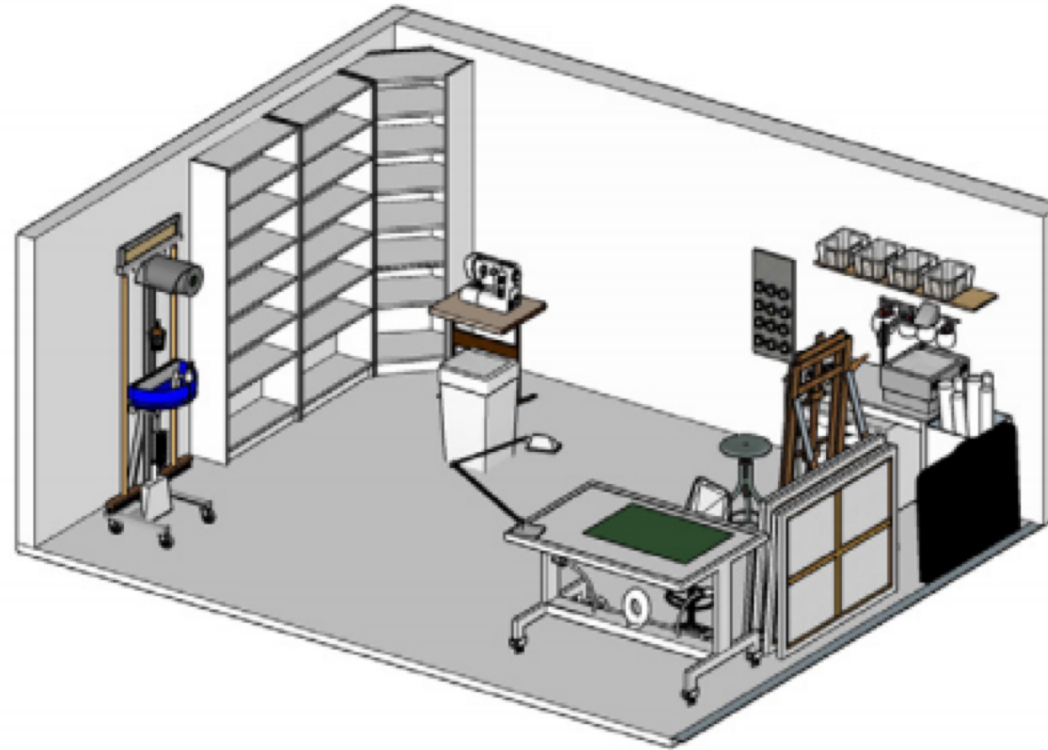
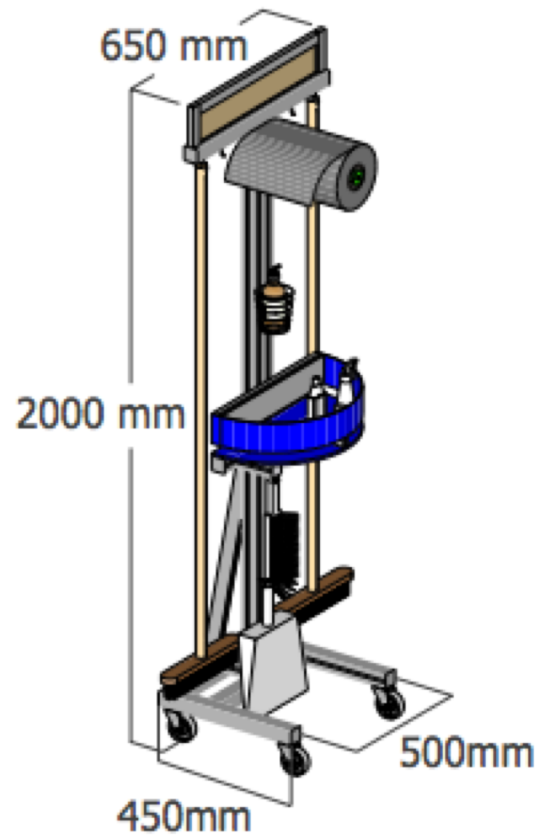

# Communication Post

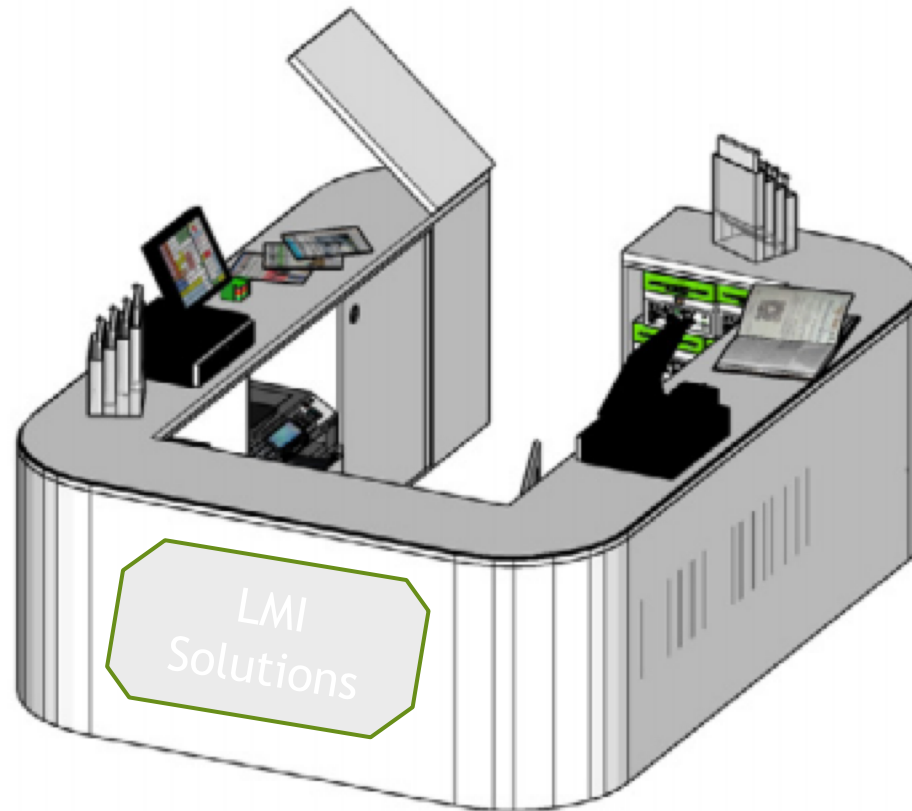
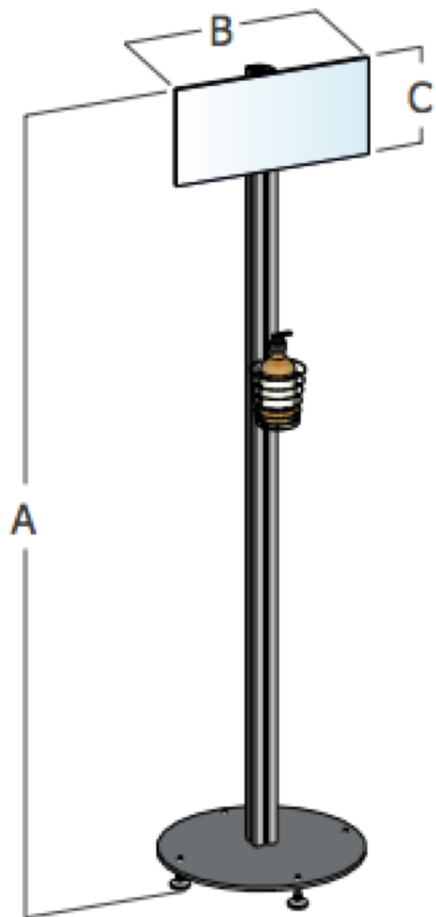

# We have solutions to suit your business

Please call 01942820088 or email [sales@lmiltd.com](mailto:sales@lmiltd.com)

You can view our website at [www.lmisolutions.co.uk](http://www.lmisolutions.co.uk)

